

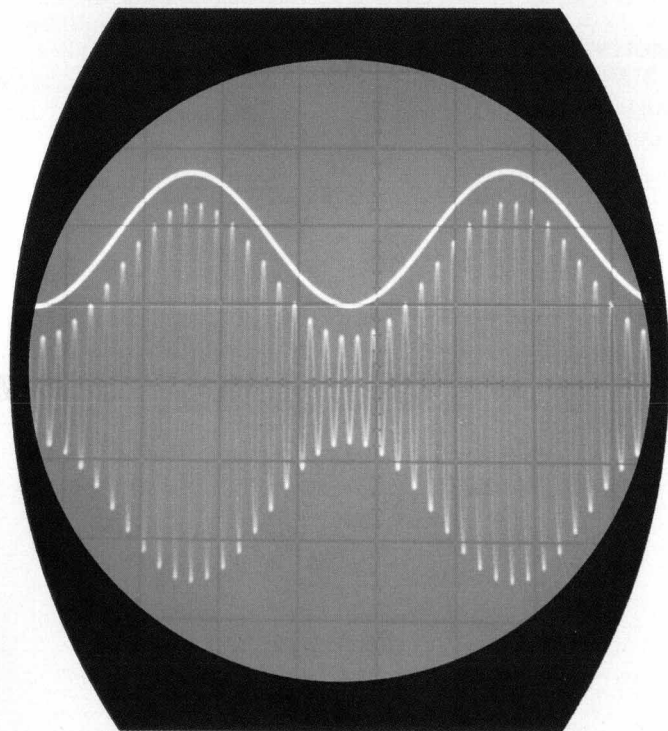

HEWLETT-PACKARD JOURNAL

TECHNICAL INFORMATION FROM THE -hp- LABORATORIES

CORPORATE OFFICES • 1501 PAGE MILL ROAD • PALO ALTO, CALIFORNIA 94304 • VOL. 17, NO. 2 OCTOBER, 1965

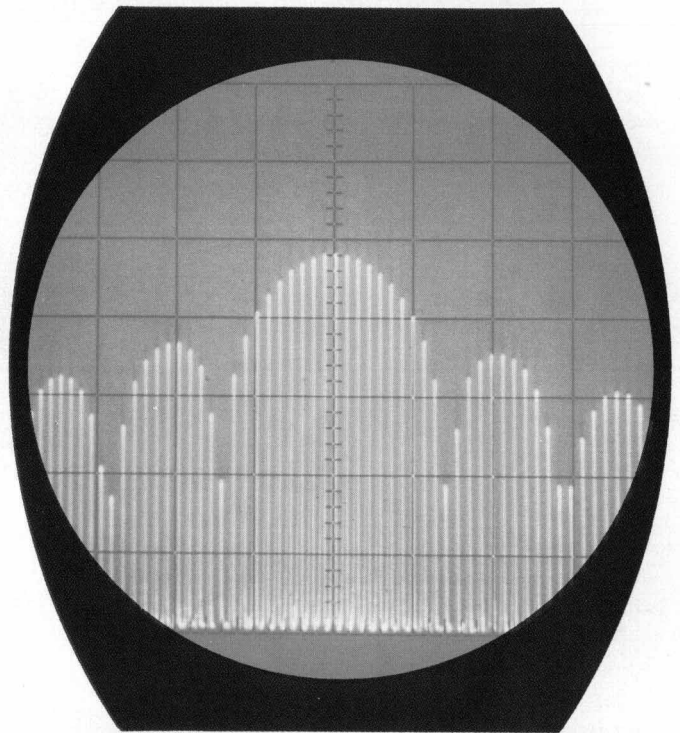
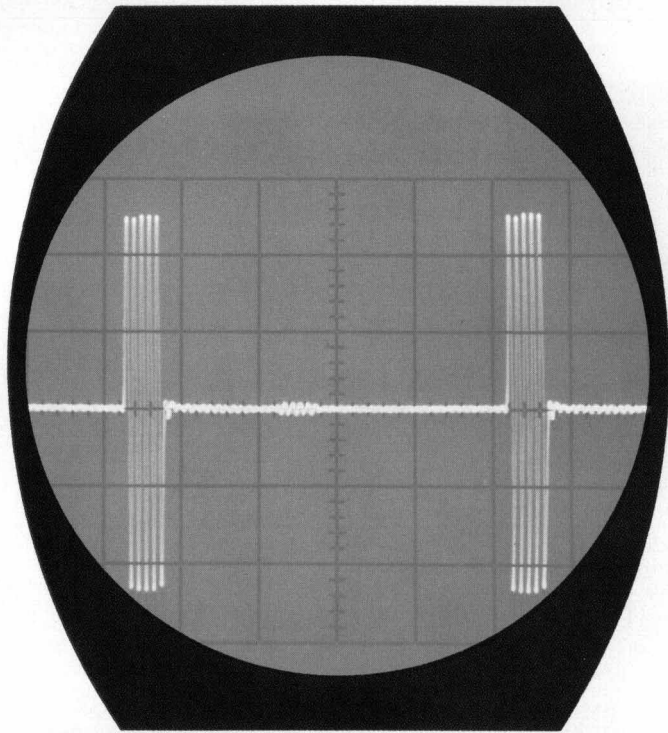

**COVER: A NEW 200 kc/s TO 500 Mc/s
UNTUNED MIXER SIMPLIFIES MANY
SIGNAL-PROCESSING APPLICATIONS; SEE P. 8**

**A PRECISION VOLTMETER MEASURES AC TO
.05% TO 10 kc AND DC TO .02%; SEE P. 2**

**BROADBAND FREQUENCY DOUBLER
PRODUCES UP TO 1000 Mc/s; SEE P. 12**

A PRECISION AC-DC DIFFERENTIAL VOLTMETER/DC STANDARD WITH HIGH VERSATILITY

A versatile new instrument measures ac voltages with high accuracy from 20 c/s to 100 kc/s by comparing the unknown to a precision dc voltage. It also measures dc voltages to 0.02% and supplies high-resolution dc voltages.

THE accuracy of ac voltage measurements has always been tempered by the lack of a primary standard of ac voltage. It is thus necessary to measure ac voltages in terms of related dc voltages that in turn can be referenced to a basic standard.

Highest accuracy in ac voltage measurements is achieved by a substitution technique that uses vacuum thermocouples to relate the ac to an accurately-known dc. Highly refined versions of this technique achieve accuracies of 0.01% but painstaking, time-consuming, laboratory procedures are required for this level of accuracy.

A new instrument now makes it possible to make ac voltage measurements to better than 0.05% accuracy in fewer steps and without the environmental restrictions or precautionary measures required of thermocouple measurements. The new instrument uses a precision rectifying circuit to convert the unknown ac directly to dc, and the resulting dc is read to 5-place resolution by a differential voltmeter technique. The measurement is straightforward in

that the ac remains connected to the converter at all times and can be monitored continuously.

THE AC-DC DIFFERENTIAL VOLTMETER/DC STANDARD

Besides a precision ac-to-dc converter, the new instrument, the -hp-

Model 741A AC-DC Differential Voltmeter/DC Standard, has the stable reference voltage source, precision resistive divider, and sensitive null indicator required for differential voltmeter measurements,¹ and it makes

¹ Robert E. Watson, "A Combined DC Voltage Standard and Differential Voltmeter for Precise Calibration Work," *Hewlett-Packard Journal*, Vol. 16, No. 9, May '65.

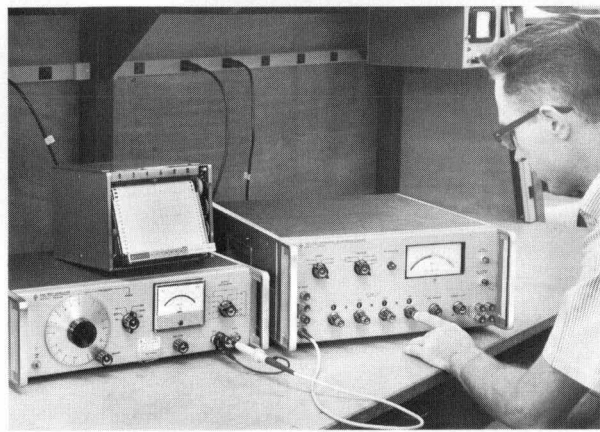

Fig. 1. New -hp- Model 741A AC/DC Differential Voltmeter/DC Standard makes highly accurate measurements of ac voltages as well as serving as dc differential voltmeter and as stable source of dc voltages. As shown here, ac differential voltmeter function is useful for calibrating oscillators and for making long term amplitude stability measurements.

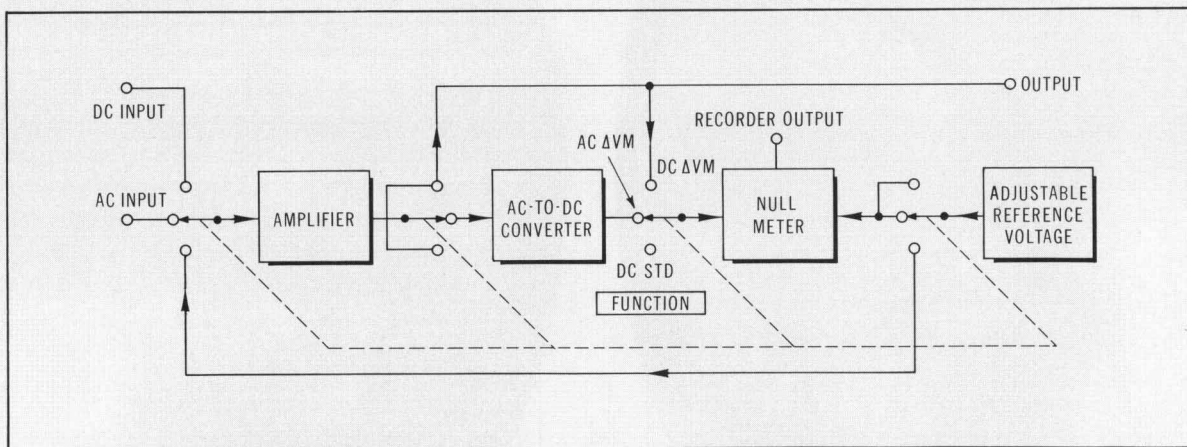

Fig. 2. Basic elements of AC-DC Differential Voltmeter/DC Standard. Function switch is set for ac differential voltmeter mode (AC Δ VM), in which Null Meter indicates difference (differential) between Adjustable Reference Voltage and dc

output of AC-to-DC Converter. In DC Δ VM mode, meter reads difference between Reference Voltage and voltage corresponding to dc input. Adjustable Reference Voltage becomes input to amplifier when instrument is in dc standard mode.

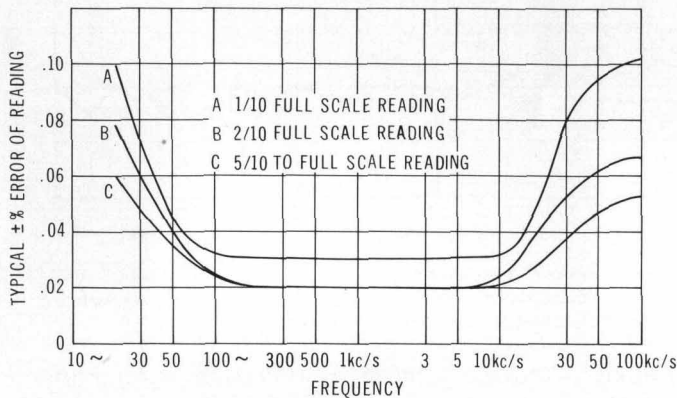

Fig. 3. Typical accuracy of new ac differential voltmeter is shown here by curves which plot errors as a function of frequency and of signal amplitude. Compensated ac-to-dc converter enables high accuracy throughout wide frequency band.

such measurements on either ac or dc voltages (Fig. 2). The instrument's circuits can also be switched to function as a highly accurate source of stable dc voltages, selectable over a range of 0 to 1000 V. In addition, the instrument is useful as a precision power or a voltage amplifier, and as either an ac or dc high-impedance, direct-reading electronic voltmeter. Obviously, the new instrument, which has many of the basic functional blocks of a secondary voltage standards laboratory, performs a variety of measurement and calibration tasks, as suggested by the capabilities summarized in Table I. It achieves this versatility, however, at a cost considerably lower than that of an assemblage of separate instruments of comparable accuracy.

As an ac differential voltmeter, the new instrument is capable of reading sine-wave voltages greater than 50 mV with an accuracy of better than $\pm 0.05\%$ of reading $\pm 0.01\%$ of end scale within a frequency range of 100 c/s to 10 kc/s. Over the full-rated range from 20 c/s to 100 kc/s, accuracy is $\pm 0.2\%$ of reading $\pm 0.01\%$ of end scale. The instrument is thus well-suited for measuring ac voltages in high accuracy amplifiers and servo systems, for measuring the stability of inverters and ac power supplies, for calibrating oscillators, for measuring the turns ratio of transformers, and for making many other precision ac voltage measurements.

The instrument also responds to signals with frequencies higher than 100 kc/s, providing indications to 500 kc/s

with accuracies typically better than 5%. Stability remains high above 100 kc/s and the instrument is thus useful for measuring the amplitude drift of oscillators and amplifiers with high resolution at any frequency up to 500 kc/s.

HIGH-IMPEDANCE INPUT

The accuracy of ac measurements is enhanced by the high-impedance probe

attached to the instrument. The input capacitance of the 1-megohm probe is less than 5 pF and this is at the point of contact with the measured circuit, three feet from the front panel.

The low capacitance results from the use of a triaxial cable. The inner shield of the cable is driven in phase with the input signal to reduce the voltage difference between center conductor and

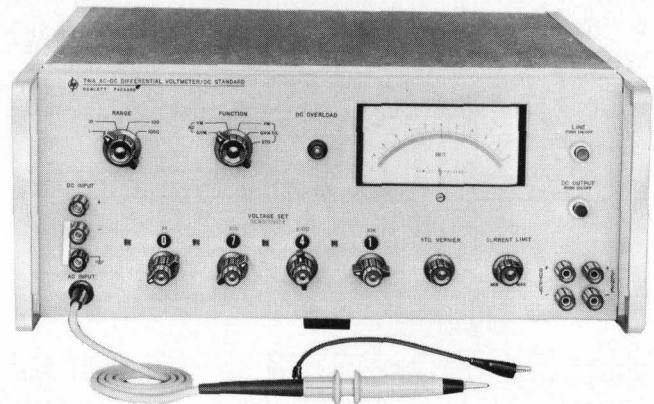

Fig. 4. New -hp- Model 741A AC/DC Differential Voltmeter/DC Standard has low capacitance probe for ac input. Probe and dc input and output are floating. Four VOLTAGE SET controls set resistive divider and push-buttons concentric with VOLTAGE SET knobs select sensitivity of front panel meter. RANGE switch sets illuminated decimal point indicators. OVERLOAD indicator lights if input voltage exceeds selected range or if output current exceeds selected limit. Overload protection to 1000 volts is provided on all ranges.

TABLE I
ABBREVIATED SPECIFICATIONS, -hp- MODEL 741A AC-DC DIFFERENTIAL VOLTMETER/DC STANDARD

Function	Ranges	Max. Reading Resolution	Accuracy	Stability	Input Impedance***
AC Δ VM	1, 10, 100, 1000 V rms	0.005% of end scale	(See below)	<0.02%/day	1 Megohm <5 pF
DC Δ VM	1, 10, 100, 1000 V	0.002% of end scale	$\pm 0.02\%$ of reading $\pm 10 \mu\text{V}$	<0.003%/day <0.005%/mo.	>10 ⁹ ohms
DC Standard	1, 10, 100, 1000 V	1 ppm	$\pm 0.02\%$ of setting $\pm 10 \mu\text{V}$	<0.003%/day <0.005%/mo.	
AC VM	1, 10, 100 mV 1, 10, 100, 1000 V	0.2 mV rms on 10 mV range**	$\pm 2\%$ of end scale above 50 mV (20 c/s-100 kc/s)**		1 Megohm <5 pF
DC VM	1, 10, 100 mV 1, 10, 100, 1000 V	0.02 mV on 1 mV range	$\pm 2\%$ of end scale		>10 ⁹ ohms
DC Power Amplifier	Unity voltage gain; input: 0 to 1000 V; output: up to 20 mA.		$\pm 0.2\%$	<0.002%/day	>10 ⁹ ohms
DC Voltage Amplifier	Gain: -60 to +60 dB in 20 dB steps, depending on RANGE and SENSITIVITY settings.				>10 ⁹ ohms
AC-to-DC Converter*	Average-responding; dc output corresponds to rms value of sine-wave input. Conversion gain is same as dc voltage amplifier.				1 Megohm <5 pF

* Output taken at rear-panel RECORDER connector; max. output: 1 V into 1k ohm.
** Below 50 mV, AC VM accuracy is 2% ± 0.2 mV (20 c/s-50 kc/s).
*** Both AC and DC inputs are floating (up to 500 V dc max.).

AC Δ VM Accuracy (% of reading)

50 mV to 1 kV	1 mV to 50 mV
0.05% +0.01% of end scale, 100 c/s to 10 kc/s	0.2% +0.02% of end scale, 20 c/s-50 kc/s
0.1% +0.01% of end scale, 50 c/s to 50 kc/s	
0.15% +0.01% of end scale, 30 c/s to 50 c/s	
0.2% +0.01% of end scale, 20-30 c/s, 50-100 kc/s	

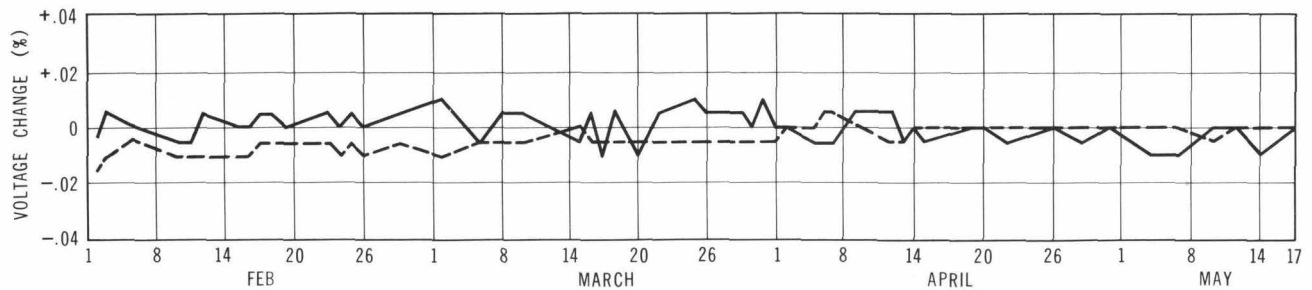

Fig. 5. Amplitude stability of Model 741A AC Differential Voltmeter is shown here by measurements made simultaneously by two instruments on one 10-volt, 1-kc/s source during period of four months. To remove drift of source from results, source voltage was adjusted to standard level by thermocouple transfer measurement prior to each measurement.

inner shield. Charging currents are thus reduced to negligible proportions. In high frequency ac measurements, the low input capacitance causes less error from source loading than does the more commonly-found instrument input capacitance of 25-50 pF, a figure which does not include the added, and often unknown, capacitance of connecting cables.

The low input capacitance is also important in measurements where capacitance loading is critical as, for example, in feedback systems where added capacitance might cause instabilities by affecting the performance of stabilizing networks. The low capacitance also makes it possible to measure

high ac voltages without drawing overly large reactive currents.

DC MEASUREMENTS

As a dc instrument, the new AC-DC Differential Voltmeter/DC Standard may be used for precision dc voltage measurements on devices such as transducers, attenuators, thermocouples, and power supplies, either differentially with 0.02% accuracy, or directly with 2% accuracy (see Table I). DC input impedance is exceptionally high (>10⁹ ohms) on all ranges regardless of whether or not the instrument is adjusted for a null reading.

As a source of dc standard voltages from 0 to 1000 volts, the new instrument, with its 0.02% accuracy and 6-place resolution on each of four ranges, is well suited for the calibration of digital voltmeters or other precision instruments. An adjustable current control limits the output current within a range of 4 to 20 milliamperes for the protection of external circuits. The in-

strument also functions as a precision power amplifier with unity voltage gain or, when the output is taken from the rear-panel recorder output, as a voltage amplifier with up to 60 dB gain.

AC DIFFERENTIAL VOLTAGE MEASUREMENTS

A block diagram of the new instrument in the ac differential voltmeter mode of operation is shown in Fig. 7. To make an ac differential voltage measurement, the voltage derived from the highly precise resistive divider is bucked against the dc output of the converter. The resistive divider is adjusted by the front panel VOLTAGE SET controls until its output equals the converted ac, as shown by the sensitive null meter. The sensitivity of the null meter, selected by the front panel SENSITIVITY controls, can be made as high as 1 mV full scale. The setting of the resistive divider thus indicates the value of the ac input voltage with high resolution.

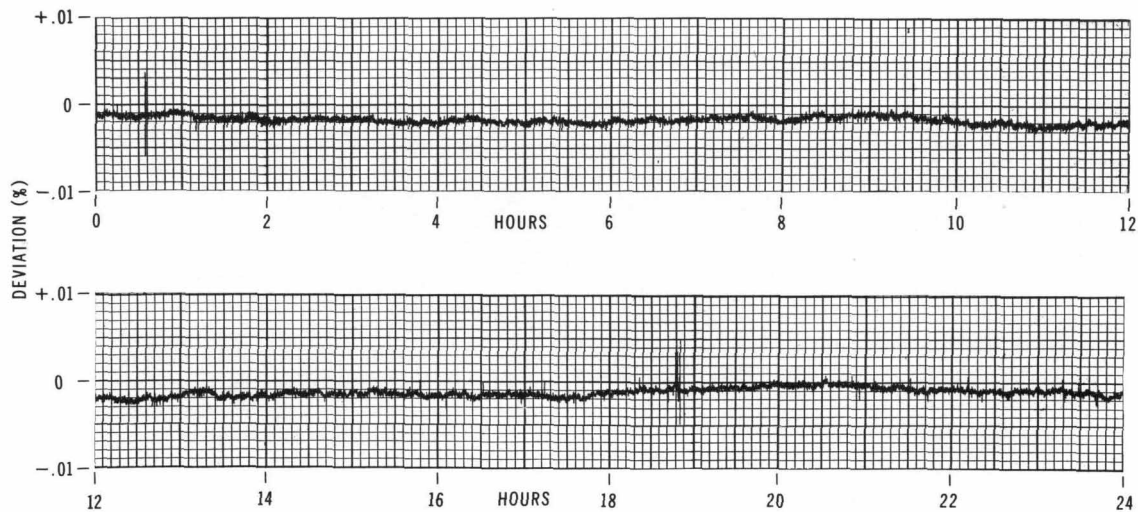
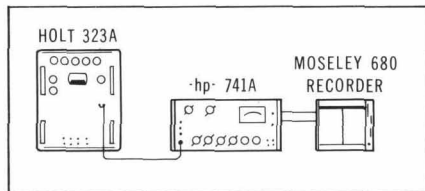

Fig. 6. Strip chart recording made during 24-hour period by Model 323A Audio Voltage Standard at 10 kc/s. Voltage Standard has specified stability of $\pm 0.02\%$ (10 seconds to 60 days).

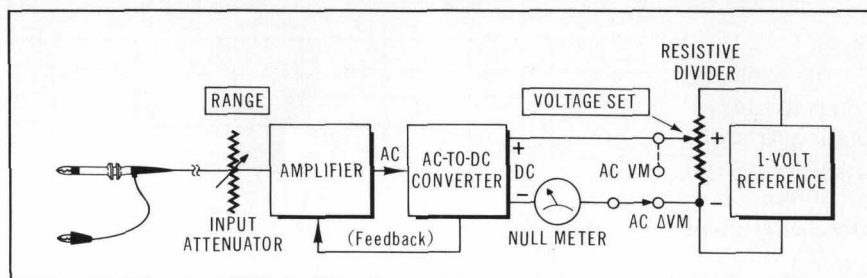

Fig. 7. Simplified block diagram of new instrument in ac differential voltmeter mode. To function as direct-reading ac voltmeter, meter circuit is switched to read converter output directly. Meter has low-drift amplifier (not shown) for increased sensitivity in either mode.

AC-TO-DC CONVERTER

The accuracies of dc differential voltmeter measurements are determined primarily by the resistive divider and the reference voltage², but in ac measurements, these are overshadowed by considerations of the accuracy of the ac-to-dc conversion. An accurate ac-to-dc converter, usable over a broad bandwidth, therefore became a prime objective in the design of the new instrument.

A simplified block diagram of the converter and related circuitry is shown in Fig. 8. A dc voltage equivalent to the average value of the ac signal is obtained by integration of the half-cycle current pulses passing through diode D2. The converter thus responds to the average value of the input waveform but the high-precision circuit constants were chosen so that the smoothed dc equals the rms value of a sine wave input.

Inaccuracies caused by the resistance change in the diodes, from 50 to 500 ohms during a 10-to-1 dynamic change in the input signal, have been made less than 0.01% by designing the amplifier to have an effective output impedance greater than 40 megohms. Diode capacitance, however, bypasses some of the signal at frequencies above 15 kc/s. This is compensated for by a low-pass filter in the feedback (Beta) network that attenuates the feedback signal at higher frequencies to increase the system forward gain. High frequency loss in the diodes is also a function of signal amplitude, hence the filter cut-off frequency is shifted according to signal amplitude. The change in cut-off frequency is caused by a voltage-variable

capacitance that has been placed in parallel with the filter capacitance and which is biased according to signal level by a voltage derived from the dc output of the converter.

With compensation thus obtained for both the frequency and the amplitude of the input signal, it has been possible to achieve accurate ac-to-dc conversion that is linear over an amplitude range from 1/10 of full scale to full scale throughout a broad frequency range (Fig. 3). With proper calibration procedures, it is possible to reduce errors to less than $\pm 0.03\%$ of reading, $\pm 0.01\%$ end scale between 100 cps and 100 kc/s under normal laboratory conditions.

LONG TERM STABILITY

Particular emphasis in the design of the new instrument was placed on achieving long term stability. Special high-frequency wire-wound resistors are used in the input attenuator and in circuit areas which determine amplifier gain stability. These resistors have temperature coefficients of less than 5

ppm/ $^{\circ}$ C and, along with the large amount of negative feedback, have made it possible to design the ac-to-dc converter to have a typical stability of 100 ppm/month, under normal conditions, and to have a temperature coefficient of less than 10 ppm/ $^{\circ}$ C between 0 and 40 $^{\circ}$ C for frequencies up to 10 kc/s. AC measurements may thus be made with stabilities that normally have been achieved only with dc measurements, and without requiring a carefully controlled environment.

The stability achieved by the instrument is shown in Fig. 5, which is a plot of measurements on one ac voltage standard made simultaneously by two of the new instruments over a 4-month period. The record shows a long-term stability of $\pm 0.02\%$ for each instrument, and the maximum deviation between instruments is only 0.01%.

Fig. 6 shows a 24-hour recording of the output of one instrument while connected to a laboratory ac voltage standard. The maximum deviation here, which also reflects the stability

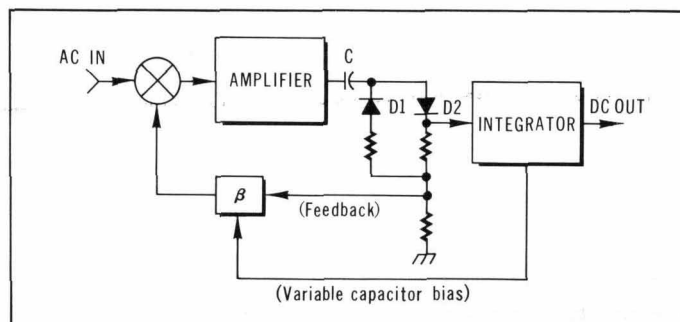

Fig. 8. Elements of precision ac-to-dc converter. Half-cycle current pulses through diode D2 are integrated to obtain output equivalent to average value of ac input. Diode D1 restores charge withdrawn by D2 from capacitor C. Two diodes working together feed full waveform to feedback network.

² See reference 1, page 2.

of the standard, is 30 ppm.

At higher frequencies, the stabilities of the high-frequency compensating capacitors influence overall instrument stability. At 50 kc/s, stability is typically better than 0.03%/month and at 100 kc/s, it is typically better than 0.1%/month.

DC FUNCTIONS

A block diagram of the new instrument operating in the dc differential voltmeter mode is shown in Fig. 10. The input voltage is applied directly to a summing point where it is opposed by the voltage output of the amplifier chain. The amplifiers function as an automatic null-seeking system that assures the equality of the two voltages. The dc input therefore has very high input impedance ($>10^9$ ohms) and this input impedance is maintained at all times on all ranges, regardless of whether or not the measuring circuits are adjusted for a null reading. The impedance of the source thus has negligible effect on the measurement and the accuracies of long-term measurements are not affected by drift in the measured voltage.

The output of the amplifier chain, attenuated if necessary to within a range of 0-1 volts, is compared to the

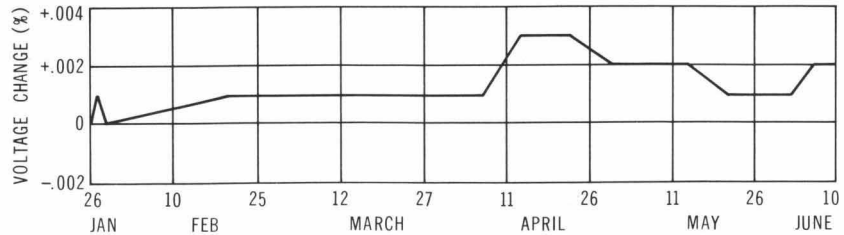

Fig. 9. Amplitude stability of new instrument in dc differential voltmeter mode plotted for period of four months while instrument monitored voltage of nine series-connected standard cells.

output of the resistive divider and the resulting difference is displayed by the null meter. The resistive divider, adjusted to bring the difference to a minimum, indicates the voltage with four-place resolution and the residual meter reading provides a fifth digit of readout.

When the instrument functions as a dc standard, the resistive divider output becomes the amplifier input, as shown in Fig. 11. An output voltage is selected by choice of the desired range, which controls the amplifier gain, and by the setting of the four VOLTAGE SET switches. These provide the first four digits of the selected voltage and a front panel VERNIER control provides the 5th and 6th digits, displayed on the front panel meter.

In the dc voltmeter modes, the voltage at the input is re-created at front panel output terminals, but with a capability for supplying up to 20 mA of current. The instrument therefore functions as a power amplifier with unity voltage gain and with the high dc input impedance that is characteristic of the dc voltmeter modes of operation. The instrument may thus be used to supply power under the control of low-power devices, such as standard cells.

In all modes of operation, a rear panel RECORDER output supplies a voltage (0-1 V) that is directly proportional to meter deflection. The instrument thus also serves as a dc voltage amplifier with up to 60 dB of gain (on the 1-volt range with $\times 1000$ meter sensitivity). Use of the RECORDER output also enables the instrument to serve as a precision ac-to-dc converter in the ac modes of operation.

DC STABILITY

The basic dc stability of the instrument is determined primarily by the 1-V reference source, the resistive divider and the range stick. The large amount of feedback makes the amplifier gains essentially independent of changes in the other parameters.

The 1-V reference voltage is derived from a pre-aged Zener diode which, along with associated circuitry, is installed in a proportionally-controlled oven. The resistors have matched temperature coefficients. The total instrument temperature coefficient in dc operation is less than 0.0003%/°C, enabling precision measurements to be made with confidence in the environment normally encountered in laboratory or production facilities. Each new instrument must exhibit an accuracy

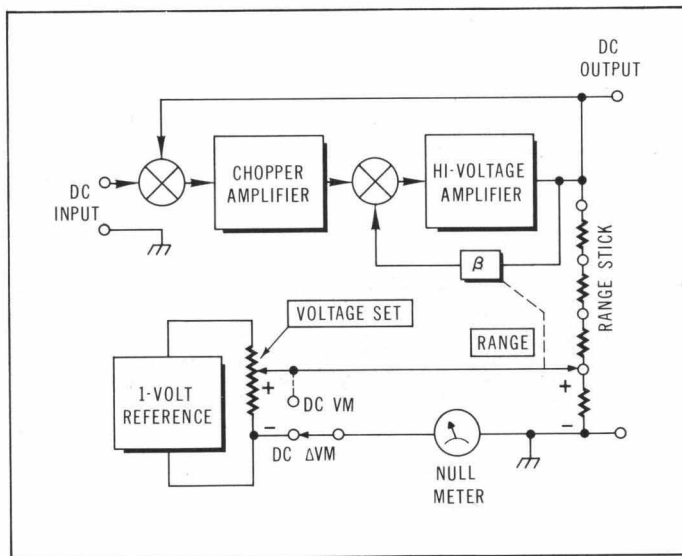

Fig. 10. Circuit arrangement for dc differential voltage measurements. AC amplifier is converted to low-drift dc chopper amplifier by addition of photoconductive modulator at input and synchronous demodulator at output. High-voltage amplifier is switched in, enabling input voltages of up to 1000 volts to be re-created at output. For use as direct-reading dc voltmeter, null meter is switched to read attenuated output voltage.

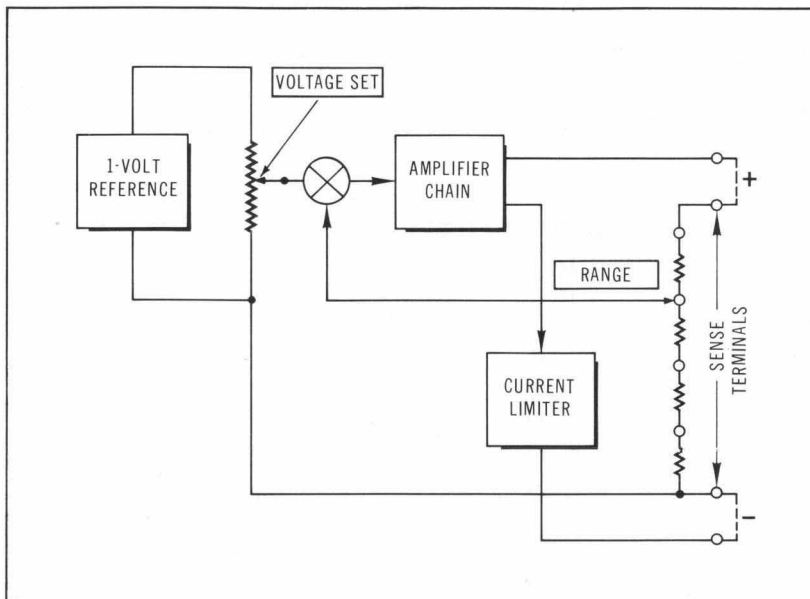
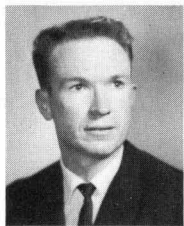

Fig. 11. In DC standard mode, output of resistive divider becomes input to amplifier chain. Summing point compares input to attenuated sample of output taken from Range stick. Amplification by factors of 10 are thus obtained by use of RANGE switch.

of better than 0.008% on all dc functions if it is to pass final factory inspection.

DESIGN LEADER



William G. Smith

Following graduation from Utah State University with a BSEE degree in 1957, Bill Smith joined Hewlett-Packard and worked on the circuitry for the -hp- Model 120A Oscilloscope. During this time, he obtained an MSEE degree from Stanford University in the -hp- Honors Cooperative program. Bill's military commission was activated on completion of his graduate studies and he spent the next three years attached to the Army's Engineering and Evaluation Section, White Sands Proving Grounds, New Mexico, in connection with the development of the Sergeant missile.

Bill rejoined -hp- in 1961, this time in the Engineering Section of the Loveland Division. Initially, he worked in power supplies and then as project leader on the Model 741A AC-DC Differential Voltmeter/DC Standard. At present he is Group Leader of the ac precision instrumentation group. Bill is a member of Phi Kappa Phi and Sigma Tau.

Fig. 9 is a typical plot of readings made in the dc differential voltmeter mode on a bank of a standard cells over a 4-month period. Typical total instrument stability is shown here to be $\pm 0.001\%$ /day or $\pm 0.002\%$ /month.

ACKNOWLEDGMENTS

The design and development team of the 741A AC-DC Differential Voltmeter/DC Standard consisted of Jerry

L. Harmon, Robert B. Moomaw, Rex James, Fred L. Hanson, Gale C. Hamelwright and the undersigned. The assistance of Robert E. Watson pertaining to the high dc input impedance has been most helpful. Appreciation is also extended to Marco Negrete for his many helpful suggestions and encouragement.

—William G. Smith

ADDITIONAL SPECIFICATIONS (See Table I) -hp- MODEL 741A AC-DC DIFFERENTIAL VOLTMETER/DC STANDARD

AC DIFFERENTIAL VOLTMETER

NULL RANGES: 1 mV to 1000 V end scale.

REPEATABILITY: Better than 0.01% on all ranges.

LINE REGULATION: $\leq \pm 0.01\%$ change for $\pm 10\%$ line voltage change.

TEMPERATURE COEFFICIENT: < 40 ppm/ $^{\circ}\text{C}$ from 20 c/s to 50 kc/s, < 60 ppm/ $^{\circ}\text{C}$ from 50 kc/s to 100 kc/s, between 0°C and $+50^{\circ}\text{C}$.

DC DIFFERENTIAL VOLTMETER

NULL RANGES: 1 mV to 1000 V end scale.

REPEATABILITY: Better than 0.001% on all ranges.

LINE REGULATION: $\leq \pm 0.002\%$ change for $\pm 10\%$ line voltage change.

TEMPERATURE COEFFICIENT: < 3 ppm/ $^{\circ}\text{C}$ from 0°C to $+50^{\circ}\text{C}$.

SUPERIMPOSED AC NOISE REJECTION: $< 0.01\%$ rms error (above 50 c/s), 50% of input or 25 V rms, whichever is less.

HIGH IMPEDANCE DC VOLTMETER

SUPERIMPOSED AC NOISE REJECTION: Same as dc differential voltmeter.

DC STANDARD

OUTPUT: Floating (up to 500 V).

OUTPUT CURRENT: 0 to 20 mA; limiter continuously variable from 4 to 20 mA. Overload indicator lights up when current exceeds selected limit.

LINE REGULATION: $< \pm 0.002\%$ for $\pm 10\%$ line voltage change.

LOAD REGULATION: $< \pm 0.002\%$ or ± 50 μV , whichever is greater, no load to full load.

TEMPERATURE COEFFICIENT: < 3 ppm/ $^{\circ}\text{C}$ from 0°C to $+50^{\circ}\text{C}$.

REMOTE SENSING: Permits output regulation at point of application.

NOISE AND HUM: dc to 1 c/s, 100 dB below full scale; 1 c/s to 1 Mc/s, 100 dB below full scale or 200 μV , whichever is greater.

DC POWER AMPLIFIER

BANDWIDTH: dc to 0.1 c/s.

LINE AND LOAD REGULATION: Same as dc standard.

NOISE: Same as dc standard.

SUPERIMPOSED AC NOISE REJECTION: Same as dc differential voltmeter.

GENERAL

RECORDER OUTPUT: Available in all modes of operation.

RECORDER AMPLIFIER: Recorder voltage output directly proportional to meter deflection. 60 dB gain (max.); 1 mA into 1 k ohm load.

POWER: 115 or 230 V $\pm 10\%$, 50 to 1000 c/s, 125 watts max.

SIZE: Nominally 16 $\frac{3}{4}$ in. wide by 7 in. high by 13 $\frac{1}{4}$ in. deep overall.

WEIGHT: Net: 46 lbs. (20.7 kg).
Shipping: 60 lbs. (27 kg).

PRICE: -hp- Model 741A: \$1475.00.

Prices f.o.b. factory

Data subject to change without notice.

A 200 kc/s-500 Mc/s FREQUENCY CONVERSION UNIT FOR MIXING, MODULATING, PHASE-DETECTING AND LEVEL-CONTROLLING

A new untuned mixer operates over the extremely wide frequency range from 200 kc/s to 500 Mc/s and uses a double-balanced circuit for high versatility.

LABORATORIES engaged in hf and vhf system and circuit development have in the past been forced to build mixers, phase detectors, and modulators as the need arose. Consequently, such units have generally been narrow-band, special-purpose items and in most cases the engineering time was not available to obtain adequate information about their performance. The new mixer described here has been designed to meet the varied needs of signal processing from 200 kc/s to 500 Mc/s with performance that compares favorably with that which could be obtained in a special-purpose unit.

From 500 kc/s to 50 Mc/s this 50-ohm mixer typically provides a single-sideband conversion efficiency less than 6 dB, flat within a small fraction of a dB, with a noise figure that does not greatly exceed this 6-dB value. A typical rejection of more than 50 dB for the high-level signal is obtained over this frequency range. This performance is approached on up to 500 Mc/s on any one of the ports.

One of the ports of the mixer is coupled to dc, thus allowing efficient operation as a low-noise phase detector, an amplitude or pulse modulator, and a current-controlled attenuator over the 200 kc/s to 500 Mc/s range.

CIRCUITRY

The circuit shown in Fig. 2 was chosen for the mixer to minimize the feed-thru from any one port to another, to provide good impedance matching at the low-signal-level ports, and to allow for several different modes of operation. The transformers were specially developed to provide very good balanced operation with a minimum of loss over the 200 kc/s to 500 Mc/s range. This balancing provides a minimum of feedthru between any two ports. The circuit is arranged so that efficient use is made of the local oscil-

lator broadband power in that both halves of the input sine wave are loaded by the diodes. With this arrangement the impedances at the "R" and "X" ports are not much greater than 50 ohms. The discussion here assumes that the new mixer is used in a 50-ohm system, but the use of a 75-ohm load at the IF, or "X," port should yield about the same results.

The diodes used are a specially-selected quad of "hot carrier" diodes produced by *hp Associates*. These diodes are closely matched, so that only a relatively small amount of higher order intermodulation products is produced. The diodes also have such a small amount of charge storage (short lifetime) that the mixing is not deteriorated by this factor even at 500 Mc/s.

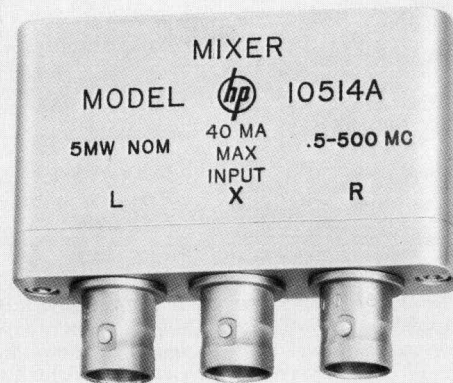

Fig. 1. New *hp*-10514A Balanced Mixer, reproduced here at full size, gives high-performance mixing over an extremely broad frequency range (200 kc/s-500 Mc/s).

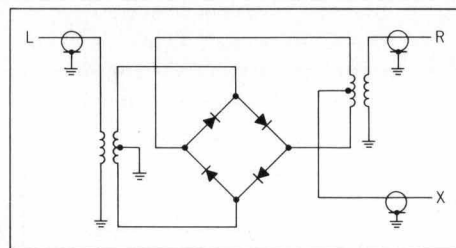

Fig. 2. Basic circuit arrangement of new broadband mixer. Circuit is double-balanced to permit efficient conversion to sum and difference frequencies with little feedthrough of input signals and low generation of intermodulation products.

CONNECTIONS

In all of the applications discussed here a nominal 5-mW level signal is fed into the "L" port. ("L" is a mnemonic designation alluding to "local oscillator" or "large" signal.) The 5-mW signal level is, however, not critical in the mixing or phase detecting modes of operation. For example, the conversion efficiency is decreased as the high-level signal is decreased as shown in Fig. 5. The "L" port has a useful frequency range of 200 kc/s to 500 Mc/s.

The "R" port (for "rf" signal port) is the normal low-level input port for mixing and phase-detecting modes. For modulation applications, this port would normally be the output port. It has a useful frequency range of 200 kc/s to 500 Mc/s.

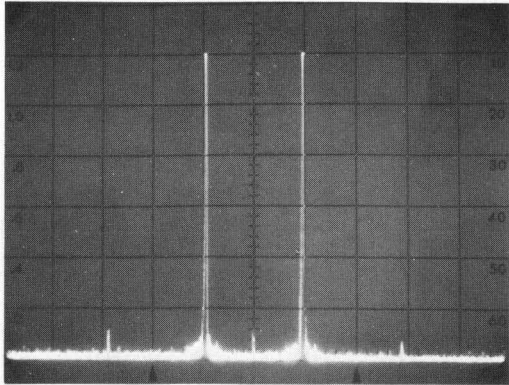

Fig. 3. Oscilloscope of spectrum analyzer presentation showing excellent carrier rejection in balanced modulator output of new mixer. A 50-Mc/s signal is being modulated by a 1-Mc/s signal. Vertical scale is 10 dB/cm so carrier rejection is well above 50 dB. Horizontal scale is 1 Mc/s/cm.

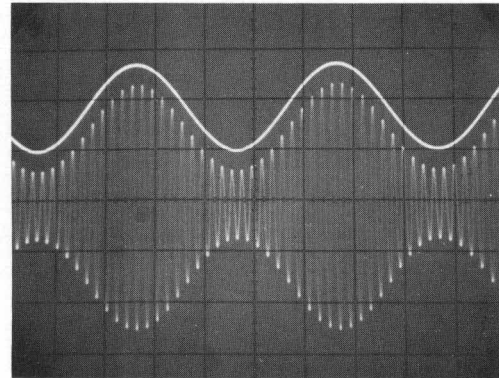

Fig. 4. Dual-trace oscilloscope showing balanced output of new mixer and the modulating waveform. Carrier was reinserted at balanced modulation output to obtain ordinary (noncarrier-suppressed) modulation, but ordinary modulation (or control of output level) can also be obtained by applying a dc current with modulating signal. Modulating signal can be any frequency from dc to 500 Mc/s.

The "X" port ("X" standing for "sum or difference" signal) is the normal output port for mixing and phase detecting modes. For modulation and attenuation applications, however, this port would normally be an input port. It has a useful frequency range of dc to 500 Mc/s. With either polarity of dc applied there will be two diodes in parallel at this port, requiring care when using external power supplies. A peak limitation of 40 milliamperes (much less than 1 volt) is specified to protect the diodes.

PERFORMANCE

When the new mixer is used as a phase detector or down-converting

mixer, single-sideband conversion efficiency like that shown (for a sample unit) in Fig. 6 can be expected. Note that the response is constant within ± 0.2 dB from 500 kc/s to 50 Mc/s. About 0.5 dB improvement in conversion efficiency can be achieved by providing a short circuit at the undesired side-band frequency at the output port. Near the 3-dB response points about the same amount of improvement can be achieved by raising the high-level signal a few dB. For an up-converting mixer the response will be quite similar to that in Fig. 6 with the output frequency taken as the abscissa.

It is expected that this unit will find application as a component in single

side-band systems. Fig. 3 shows the suppressed-carrier modulation performance obtainable in the hf frequency range. Note that the vertical scale is 10 dB per cm, showing that the carrier is suppressed by well over 50 dB. With carrier suppression like this, the carrier rejection requirements placed on an associated single sideband filter are greatly reduced. Also, carrier rejection of this degree allows the possibility of generating a more than acceptable single-sideband by the phasing method. Balance is a very important feature of the mixer and the specifications give limit feed-thru values which should be of interest for general signal-processing applications. These conservative levels show, for example, the amount of isolation between the local oscillator and the IF port (in a receiver application) without the benefit of filtering.

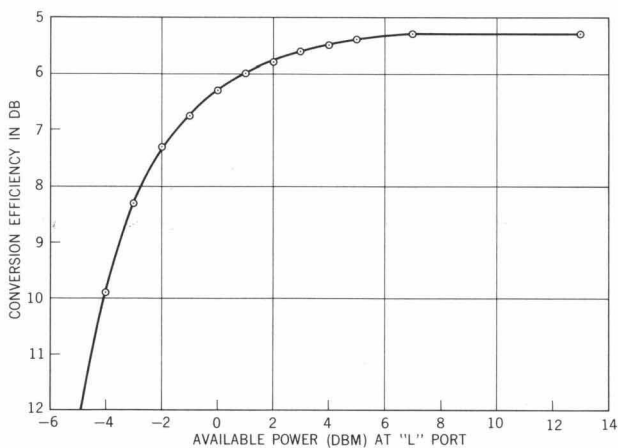

Fig. 5. Single side-band conversion efficiency of a typical mixer as a function of power available from a 50-ohm source. Input signals at 1 Mc/s with lower-level input at 10 mV.

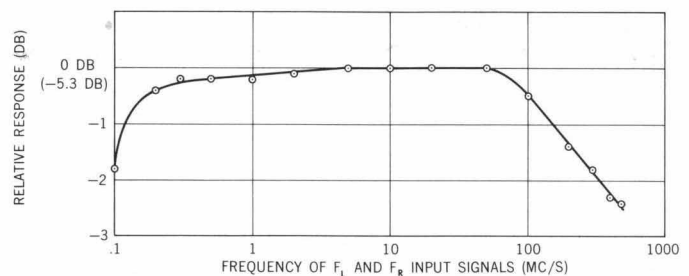
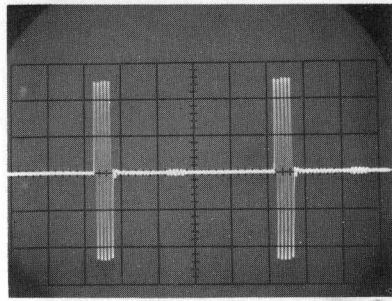
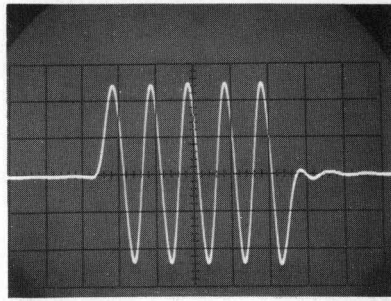

Fig. 6. Relative frequency response of a typical mixer used as a down-converting mixer. The lower-frequency input F_L was at +7 dBm, the higher F_R at -3 dBm. 0-dB reference was 5.3 dB conversion efficiency.



(a)



(b)

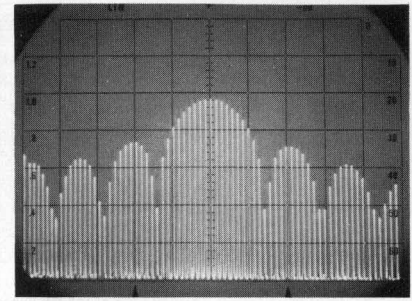

(c)

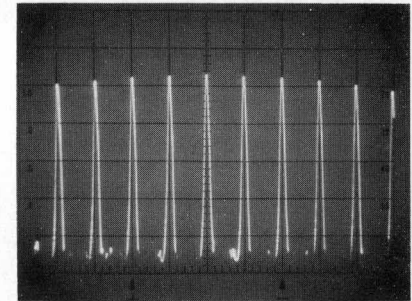

(d)

Fig. 7. Oscillograms showing fast-pulse modulation performance of new mixer. Modulating pulse is $0.1 \mu\text{sec}$ wide, repetition rate is 1 Mc/s , carrier is 50 Mc/s . (a) shows clean rf pulses obtainable. (b) is (a) expanded 10 times to show more clearly the precise turn-on and turn-off capability of the mixer. (c) is a spectrum analyzer presentation of modulated carrier showing dispersion and envelope of spectral components on a log scale (10 dB/cm). (d) is a frequency expansion of (c) and more clearly suggests the use of pulse modulation with the mixer as a spectrum or comb generator. Vertical scale is 10 dB/cm and horizontal is 1 Mc/s/cm .

The new mixer can be converted from a suppressed carrier modulator to an amplitude modulator (with good control of the amplitude level) by adding some dc current with the modulating signal (Fig. 4). The dc current can be adjusted to control the amplitude modulation level by unbalancing the diode bridge.

The last application leads naturally to the thought of pulse modulation. The mixer's capabilities in this area are shown in Figs. 7(a) to (d). These oscillograms show the quality of pulse modulation obtained using short, high-repetition-rate pulses. A 1-Mc/s repetition rate, 300-mV , 10^{-7}-sec -wide pulse was applied at the "X" port, and a 500-mV , 50-Mc/s signal at the "L" port. Fig. 7(a) shows the mixer output on a linear vertical scale as a function of time with a $2 \times 10^{-7} \text{ sec/cm}$ sweep. Fig. 7(b) is a time expansion of this to show more detail at $2 \times 10^{-8} \text{ sec/cm}$. Fig. 7(c) shows the output on a log vertical scale as a function of frequency with a 7 Mc/s/cm sweep. Fig. 7(d) is a frequency expansion at 1 Mc/s/cm .

CURRENT-CONTROLLED RF ATTENUATOR

As a straight current-controlled attenuator the performance at 50-Mc/s is shown in Fig. 8. A 50-Mc/s signal at a level of $+3 \text{ dBm}$ (a larger input will result in greater insertion loss) was

applied to the "L" port. The dc control current was then applied to the "X" port, and the output taken from the "R" port. Note the low insertion loss and the 50-dB range over which the attenuation is highly linear with control current. The second harmonic content in the output in this mode of operation is quite low, as shown in Fig. 8, while the third harmonic can be easily blocked from following circuits by a simple filter. The 40-mA limit value of current mentioned earlier also applies

in this work and a series resistor of sufficient value should be used directly in series with the "X" port.

For general signal processing, the mixer intermodulation product levels are of considerable interest. These signal levels are ordinarily troublesome to measure, so as a convenience to the user typical values are given in the

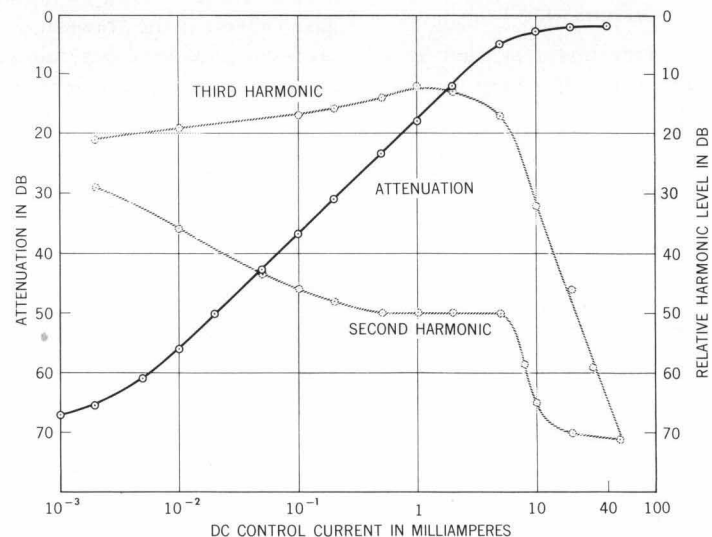

Fig. 8. Typical attenuation (solid line) at mixer output ("R" port) of a signal applied to "L" port as a function of a dc control current applied to "X" port. (See also Fig. 4.) 0 dB is $+3 \text{ dBm}$ input level. Input signal is 50 Mc/s . Shaded lines show relative harmonic content in mixer output vs. control current for a typical mixer. 1 Mc/s input signal level at $+3 \text{ dBm}$.

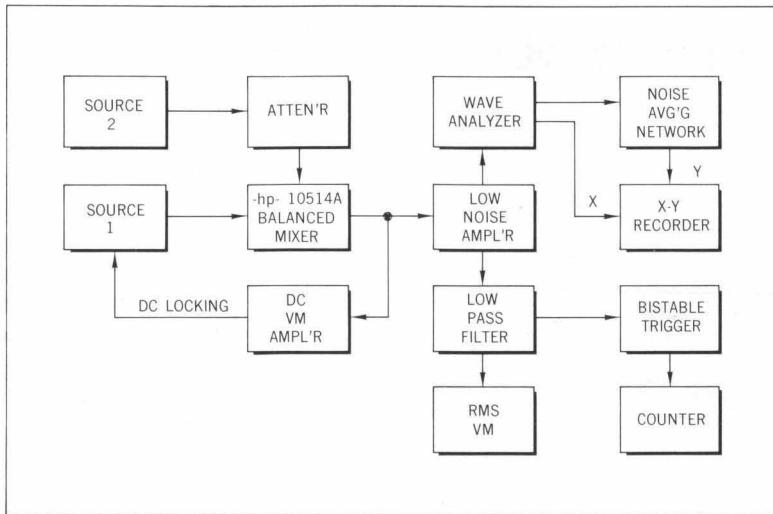

Fig. 9. Block diagram of measurement arrangement using new mixer in evaluating short-term stability of high-quality signal sources.

specifications for distortionless inputs at a particular f_R level with resistive terminations. This performance is significantly better than that measured with other diode mixers evaluated. These intermodulation products are not a strong function of the high-level signal, but they are highly dependent on the low-level signal. A reduction in the low-level signal will greatly reduce the intermodulation levels.

FREQUENCY STABILITY MEASUREMENTS

When used as a phase detector, the new mixer is valuable in determining the short-term stability of high-quality signal sources. Two signal sources can

be applied to the mixer to translate the instability down to a lower frequency for easier evaluation. If the two signals are adjusted to the same frequency and to quadrature phase position, the output phase noise can be monitored with a low-frequency analyzer for phase noise plots. A band-limited voltmeter can be used for a gross measure, as can a frequency counter for averaged time sample measurements (by providing some frequency offset of the signals to be checked). With a suitable low-noise amplifier placed after the mixer, the performance of the highest quality signal sources can be evaluated. A block diagram for this application is shown in Fig. 9. The DC LOCKING line is broken when a frequency offset is used for counter measurements. If the sources are both of the type to be evaluated, the noise power from each is generally considered equal and the results are improved by 3 dB to represent the performance of a single source.

ENVIRONMENTAL PERFORMANCE

The mixer was designed to withstand adverse environmental conditions. For less severe conditions this ability is generally considered a measure of reliability. This mixer has been type tested to meet its specifications over 0 to 55°C and thru five cycles of 40°C and 95% humidity. Other tests include -40°C to +75°C exposure, 0.01 inch peak-to-peak vibration to 55 cycles, 4 inch bench drop, and altitude

DESIGN LEADER



Victor E Van Duzer

Vic Van Duzer obtained a BSEE degree from the University of Illinois in 1957 and an MSEE degree at Stanford University in 1959. He has been with Hewlett-Packard from 1958 to present, working as a development engineer and a development section manager. His development work has included sampling oscillography, very fast rise-time pulse generation, and frequency synthesis. Mr. Van Duzer has patents and applications for patents filed in these areas of development.

SPECIFICATIONS

-hp-

MODEL 10514A

DOUBLE BALANCED MIXER

INPUT/OUTPUT FREQUENCIES: "L" and "R" ports: 200 kc/s to 500 Mc/s; "X" port: dc to 500 Mc/s.

MAX. INPUT: 40 mA max.

IMPEDANCE: Designed for use in a 50-ohm system.

MIXER CONVERSION LOSS:

(A) 7 dB max. for f_L and f_R in the 500 kc/s to 50 Mc/s range and f_X from dc to 50 Mc/s (f_L level at 5 mW and f_R level less than 1 mW).

(B) 10 dB max. for f_L and f_R in the 200 kc/s to 500 Mc/s range and f_X from dc to 500 Mc/s (f_L level at 5mW and f_R level less than 1 mW).

NOISE PERFORMANCE:

8 dB max. noise figure for conditions of (A) above except f_X min. frequency of 50 kc/s.

11 dB max. noise figure for conditions of (B) above except f_X min. frequency of 50 kc/s.

10⁻⁷ volts per root cycle max. at output for conditions of (A) or (B) except f_X at 10 cycles.

MIXER BALANCE:

AS IN (A)	AS IN (B)	
40 dB	40 dB	f_L at R with f_L reference
45	30	f_L at X with f_L reference
45	30	f_R at L with f_R reference
25	10	f_R at X with f_R reference
40	10	f_X at L with f_X reference
25	5	f_X at R with f_X reference

TYPICAL COMPRESSION: By f_{R2} signal presence interfering with f_{R1} signal (f_L level at 5 mW):

1 dB for f_{R2} level of 1 mW.
10 dB for f_{R2} level of 10 mW.

INTERMODULATION: Typical intermodulation product production with f_L level of 5 mW and f_R at 70 mV:

Product	Level referred to f_X level
$2f_L - f_R$	35 dB
$3f_L - 2f_R$	70
$4f_L - 3f_R$	70
$5f_L - 4f_R$	85
$6f_L - 5f_R$	90
$7f_L - 6f_R$	100
$2f_R - f_L$	60 dB
$3f_R - 2f_L$	55
$4f_R - 3f_L$	85
$5f_R - 4f_L$	75
$6f_R - 5f_L$	95
$7f_R - 6f_L$	85

CONNECTORS: BNC.

DIMENSIONS: 2.3 in. x 0.6 in. x 1.8 in. (59 x 15 x 47 mm)

MOUNTING: Tapped 4-40 NC hole pair on 2.062 in. centers on connector side.

WEIGHT: 5 ounces (140 grams).

PRICE: \$250.00.

Note: All specifications are for 50Ω terminations and f_L level of 5 mW.

Prices f.o.b. factory.
Data subject to change without notice.

to 15,000 feet while operating. One of the most important environmental features of this unit is the type test compliance with rigid RFI specifications such as MIL-I-6181D.

-Victor E Van Duzer

500 kc/s-500 Mc/s FREQUENCY DOUBLER

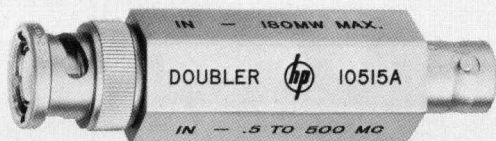

Fig. 1. New -hp- 10515A Frequency Doubler (shown actual size) produces outputs from 1 to 1000 Mc/s from inputs of 0.5 to 500 Mc/s and thus doubles the usable frequency range of existing signal sources.

IT IS OFTEN valuable to be able to increase the frequency coverage of signal generators, frequency synthesizers and other signal sources. To permit this, a new broadband frequency doubler has been designed which operates on inputs from 500 kc/s to 500 Mc/s, yielding outputs from 1 to 1,000 Mc/s. The doubler is extremely convenient (see photo), has a quite flat frequency response with a 10-dB conversion efficiency, and has high rejection of the first and third harmonics of the input.

The doubler uses a pair of matched hot-carrier diodes in a circuit that is

optimized for use in a 50-ohm system. The frequency response of the output is typically constant within 1 dB from 1 to 1,000 Mc/s for input signals between 5 and 180 mW and an output load of 50 ohms resistive. On single frequency input, the rejection of the first and third harmonics of the input is typically greater than 30 dB relative to the desired output. This rejection applies for highest rated frequencies; for outputs in the region from 1 to 100 Mc/s the rejection of the first and third harmonics is typically greater than 45 dB.

The device can also be used as a broadband ac-to-dc converter by operating it without an external dc return path.

—Victor E Van Duzer

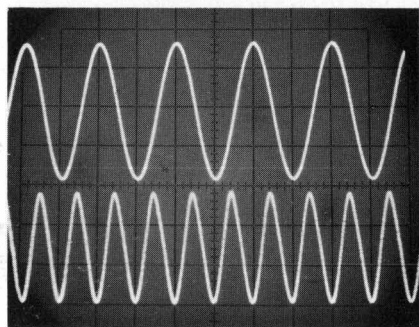

Fig. 3. Dual-trace oscilloscope presentation of typical operation of new doubler showing relative absence of undesired output components. Input (top) to doubler is a 1-volt, 500-Mc/s signal; corresponding 1000-Mc/s output (lower) is delivered to external 50-ohm load. At lower operating frequencies the output will typically contain somewhat more fourth harmonic and appear more like full-wave rectification.

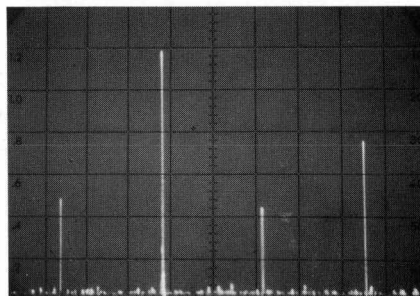

Fig. 4. Spectrum analyzer presentation of typical output of new doubler when driven by a 1-volt, 500-Mc/s input. First through fourth harmonics are displayed. Vertical scale is 10 dB/cm; thus more than 30 dB rejection occurs for first and third harmonic.

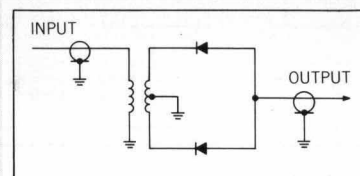

Fig. 2. Basic circuit of new doubler. Use of balanced circuit achieves high rejection of first and third harmonics. Doubler can be used as a very broadband AC-DC converter if no external dc return is used.

SPECIFICATIONS

-hp-

MODEL 10515A FREQUENCY DOUBLER

FREQUENCY RANGE: 0.5-500 Mc/s input
1-1000 Mc/s output

IMPEDANCE: 50 ohm nominal (source and load).

INPUT SIGNAL VOLTAGE: 0.5-3.0 Vrms.

INPUT SIGNAL POWER: 180 mW (max.).

CONVERSION LOSS:*
< 12 dB (typically < 10 dB) for > 1 volt,
0.5 to 50 Mc/s input.
< 13 dB (typically < 11 dB) for > 0.5 volt,
0.5 to 500 Mc/s input

SUPPRESSION OF 1ST AND 3RD HARMONIC OF INPUT:*
> 35 dB for 0.5 to 50 Mc/s input (typically > 45 dB).
> 20 dB for input to 500 Mc/s (typically > 30 dB).

ENVIRONMENTAL PERFORMANCE: Type tested to 0-55°C, 40°C/95% humidity, and compliance with MIL-I-6181D interference specification.

DIMENSIONS:
DIAMETER: 0.7 in. (18 mm).
LENGTH: 2.5 in. (64 mm).

CONNECTORS:
INPUT: BNC male.
OUTPUT: BNC female.

WEIGHT: Approximately 2 ounces (56 grams).

PRICE: \$120.00.

Prices f.o.b. factory.

Data subject to change without notice.

* With a 50-ohm resistive load and a single input frequency. Suppression values are referred to the desired output level.

WHICH DC VOLTMETER?

The meaning of voltmeter specifications, techniques for calibrating high accuracy dc voltmeters, and methods of dealing with extraneous noise in dc voltage measurements are some of the topics discussed in a new application note, "Which DC Voltmeter?", available without charge from Hewlett-Packard. Other articles in the application note survey the various types of analog and digital dc voltmeters, review the advantages and limitations of each type, and comment upon the factors to be considered in selecting a dc voltmeter.

To obtain a copy, ask your nearest -hp- field office for -hp- Application Note No. 69 or write:

Hewlett-Packard Loveland Div.
P.O. Box 301
Loveland, Colo. 80537